

## VULNERABILITY ASSESSMENT OF A 3-STORY STEEL BRACED FRAME WITH KHORJINI CONNECTIONS AND INFILLS IN TEHRAN

Amir KIANI

*Ph.D. Candidate, International Institute of Earthquake Engineering and Seismology, Tehran, Iran  
a.kiani@iiees.ac.ir*

Babak MANSOURI

*Assistant Professor, Dept. of Emergency Management, International Institute of Earthquake Engineering and Seismology, Tehran, Iran  
mansouri@iiees.ac.ir*

Abdolresa S. MOGHADAM

*Assistant Professor, International Institute of Earthquake Engineering and Seismology, Tehran, Iran,  
moghadam@iiees.ac.ir*

**Keywords:** Semi-rigid Khorjini Connections, IDA, Fragility Curves, Performance-based Evaluation, Infill Walls

### ABSTRACT

Connection failure of extremely large number of steel buildings with semi-rigid "Khorjini" connections has been reported in past major earthquakes in Iran (i.e. Bam-2003 and Manjil-1990). In the present paper, atypical 3-story steel braced-frame building with "Khorjini" connections with infill wall is selected and the incremental dynamic analysis (IDA) is performed to investigate its seismic performance. The probability of exceeding desired performance limits on future probable earthquakes in Tehran are estimated for Tehran. In order to develop such fragility curves, 44 records as offered by ATC-63 are adjusted for the study area and used to perform nonlinear analyses. IDA-generated fragility curves are presented for Immediate Occupancy (IO), Life Safety (LS) and Collapse Prevention (CP) limit states performance. The results showed 56% probability of exceeding the CP performance level for earthquakes with a return period of 2475 years. For return period of 475 years, this value was 16%.

### INTRODUCTION

The 2006 census data for Iran indicated a total of 82% of the housing units as masonry or steel constructions. 47.3% of these housing units are categorized as low seismic resistant constructions. For Tehran, low quality steel or masonry housing units account for about 50% of the total housing units. For city of Sari in northern Iran (2011 census data), the above figure is 43% of the dwellings. Also it is noted that the Khorjini type steel structures were very popular in larger cities two to three decades ago because of the simplicity of the method and the relatively low cost of the construction.

In such frames, continuous parallel beams cross and encase several columns and the joints are formed by welding two angle sections on each side of the column intersection and at the top and on the bottom of the beam flanges. A popular and typical configuration of such connection is shown in Fig. 1. Collapse of large number of buildings in past major earthquakes in Iran such as Manjil (1990) and Bam (2003) events has been reported by different researchers.



Figure 1. Reported brittle connection failure and roof collapse at Bam earthquake, 2003

Although there is no high rigidity at Khorjini connections for proper moment transfer (with initial rotational stiffness about 900 ton.m/rad), but due to shear and torsional capacities for the connecting angle sections, these joints are generally categorized as semi-rigid. The rotation moment curves for Khorjini beam connections has been obtained by experimental tests carried out by Karami and Moghadam (1991), Mazrouei and Mostafaei (1999) and Amiri and Aghakouchak (2011). The latter provided the moment-rotation curves for six different Khorjini connections using different beam sections and connection angle sections. They found that the length of the connecting angle section played major role in the strength of the connection.

In this paper, Open System for Earthquake Engineering Simulation (OpenSees) platform (McKenna et al. 2000) is used to perform the Incremental Dynamic Analysis (IDA) on selected building model in order to derive the probability of exceeding different maximum inter-story drift ratios. As to estimate the corresponding damage measures for each structure, Immediate Occupancy (IO), Life Safety (LS) and Collapse Prevention (CP) limit states are assigned for all forty four IDA curves. The derived fragility curves are utilized for computing the probability of different structural damages for 475 and 2475 years return period hazard levels for the site.

## MODELLING

Studying some as-built drawings and site inspections of a number of steel frame buildings with Khorjini connection at Tehran assisted to reveal the general specifications for some typical beam, column and bracing sections, connection details and thickness of infill walls. As a result, a three-bay (span length of 5.0 m) frame with 3 stories (story nominal height of 3.2 m) were considered. (Fig. 2 and Fig. 3). These buildings are generally constructed without proper seismic considerations (i.e. weak bracing section, etc...). The modeling assumptions are as described in the following sections.

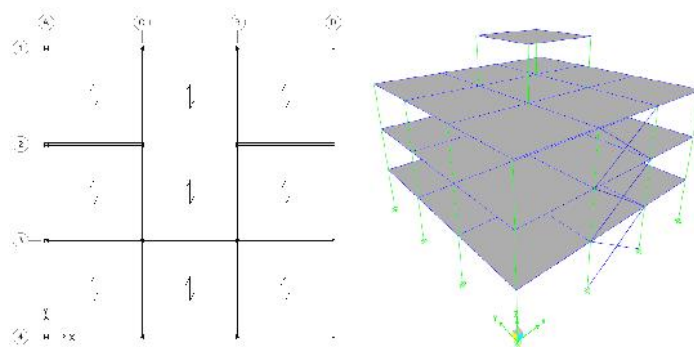

Figure 2. Plan view and 3D view of 3-story conventional building models

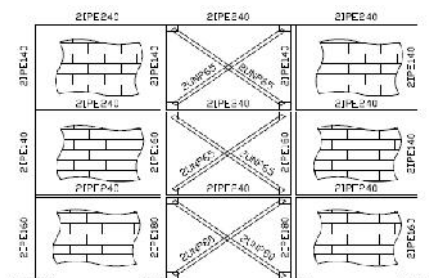

Figure 3. Schematic view of 3-story building model

## MODEL NG KHORJINI CONNECTIONS

Crossing continuous beams at each column sides are modeled separately to take into account the effect of both encasing beams. Semi-rigid characteristics for the connections are considered by adding rotational springs on each side of column at every joint locations. Somerotation moment curves for Khorjini beam connections has been obtained from experimental tests carried out by Amiri and Aghakhouchak (2011). The moment-rotation curve for the most common connection type (as shown in Fig. 4) is utilized in nonlinear modeling of the connections where IPE 240 is considered for the beam sections, and L-10 (10mm thickness) angle section at top and L-12 (12mm thickness) angle section at bottom (with 20 cm length) and medium quality welding were taken into account. Since very little test data is available for the hysteretic behavior of such connections, moment-rotation curve of Fig. 4 is considered as the envelop curve for a bilinear hysteresis curve according to the Modified Ibarra Krawinkler Deterioration Model.

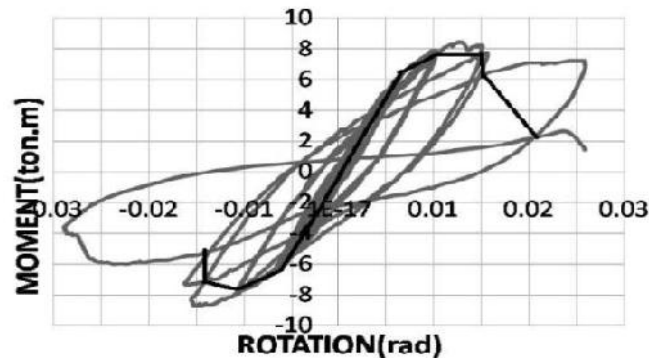

Figure 4. Moment-rotation curve of Khorjini connections utilized in this study Amiri and Aghakhouchak (2011)

## MODEL NG MASONRY INFILL WALLS

The failure mechanisms in the infill panel are rather complicated. These failures are associated with the horizontal slip, diagonal cracking, corner crushing. In this study, the cyclic behavior of the infill masonry panel has been modeled by adopting the hysteresis rule proposed by Crisafulli (1997) for its relative sophistication. This model considers the nonlinear behavior of masonry infill in compression by a limited hysteretic behavior with pinching effect due to the cracked materials. Based on this model, the hysteretic behavior of struts is derived as shown in Fig. 5(b). In order to obtain satisfactory agreements between analytical and experimental results, the final model parameters (some basic parameters are shown in Table 1) are implemented into the Modified Ibarra-Medina-Krawinkler Deterioration Model with pinched hysteretic response in order to properly model the cyclic behavior of struts in OpenSees software.

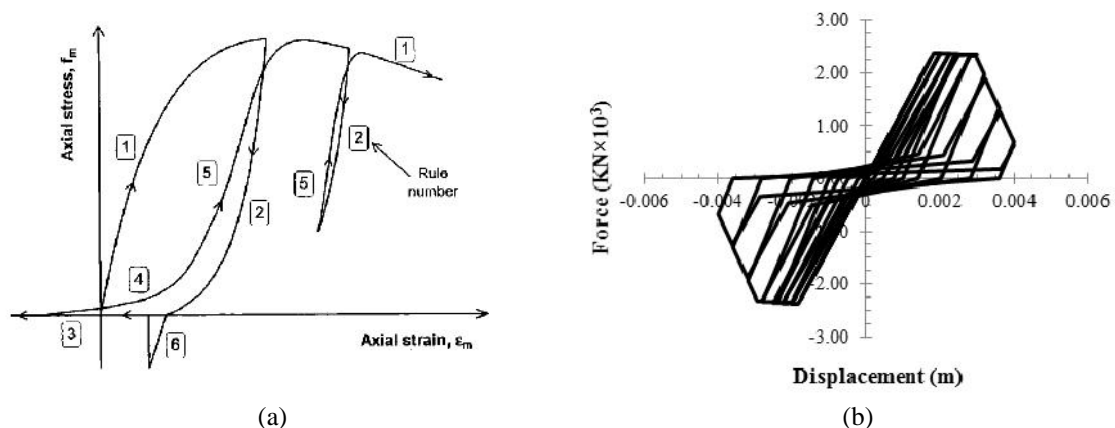

Figure 5. (a) Crisafulli's model for modeling hysteretic behavior of struts, (b) Hysteretic behavior of struts by Modified Ibarra-Medina-Krawinkler Deterioration Model

The elastic modulus, the minimum lower bound for the average compressive strength, limit state strains and the width of struts are calculated using empirical recommendations of FEMA-356, and a study conducted by Garivani et al. (2012) as summarized in Table 1.

Table 1. Struts mechanical properties

Minimum lower bound of average compressive strength ( $f_{mcl}$ )	2.0 Mpa
Expected compressive strength ( $f_{me}$ )	2.4 Mpa
Expected elastic modulus	1320 Mpa
Compressive strain at ultimate strength	0.0020
Ultimate strain	0.0040

## VALIDATION OF NUMERICAL MODEL

In order to evaluate the adequacy for the infill panel modeled using OpenSees software, the response from the simulation and the experimental results obtained from quasi-static cyclic test by Crisafulli (1997) were compared as shown in Fig. 6. The geometric details for the test setup is summarized in Table 2. The comparison shows a good fit between numerical and experimental results in terms of global response. The model adequately explains the stiffness, the strength and the energy dissipation.

Table 2. Setup detail of Crisafulli (1997) infill test

Span Length (mm)	Height of Frame (mm)	Infill Thickness (mm)	Dimensions of Infill Panel (mm)	Beam Section (mm)	Column Section (mm)
2800	2200	100	2000 × 2500	150 × 200	150 × 150

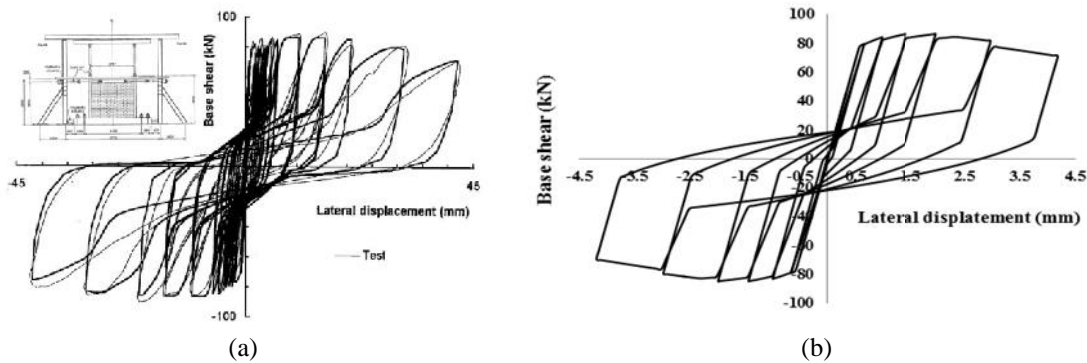

Figure 6. (a) Experimental outputs of Crisafulli (1997) test, (b) Numerical modeling

Also, the experimental data of one-story X-CBF (X-type concentrically braced frame) tested by Wakabayashi et al. (1974) has been used to assess the adequacy of numerical modeling for the braced frame. The details of the test are explained in Table 3. Numerically, both beams and columns were modeled as distributed plastic elements with 5 integration points (IPs) and 20 fibers per section. The simulated cyclic performance of the X-CBF specimen is compared with the experimental results in Fig. 7.

Table 3. Setup detail of Wakabayashi et al. (1974) X-braced frame test (in mm)

Span Length	Height of Frame	Bracing Section	Beam Section	Column Section
5000	2600	H-100×50×4×6	H-250×125×6×9	H-175×175×7.5×11

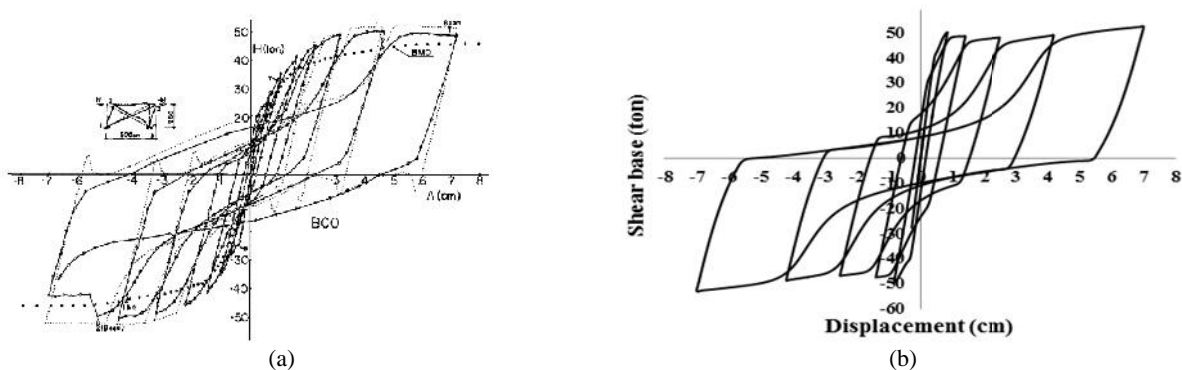

Figure 7. (a) experimental data (Wakabayashi et al., 1974), (b) numerical data for X-CBF



## NUMERICAL INVESTIGATION ON PERFORMANCE LIMITS

The structural system of interest is modeled and the damages to these structures are diagnosed according to the stiffness and strength degradation. Fig. 8 show the capacity (pushover) curves of the 3-story frame and the structural behavior for 3-story frames under cyclic loads.

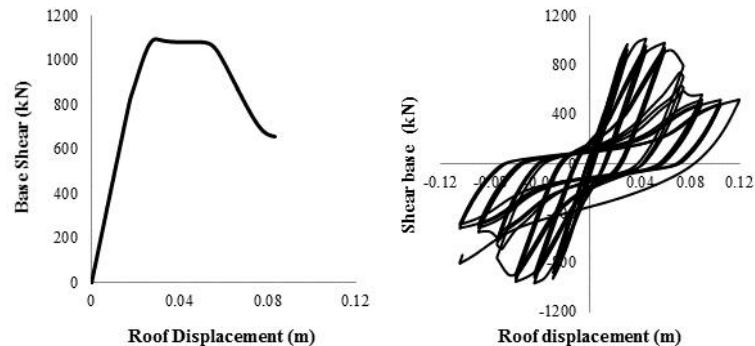

Figure 8. Structural behavior of Khurjini frame under cyclic load and pushover result

Studying Fig.8, it could be concluded that a system with a combination of bracings and infill walls experiences two main stages until failure and the resulting hysteresis behavior exhibits a bit higher energy dissipation as compared to either frame with bracing only or frame with infill wall only cases. In the first stage, the behavior is dominated by the stiffness degradation of infill walls. After a quick transitional phase, the behavior is supported by the bracing only.

Fragility curves are useful in evaluating the seismic vulnerability of the desired structural type. In order to develop fragility curves, different damage state limits must be defined. As suggested by FEMA-350, HAZUS and FEMA-356 the inter-story drift is considered as the primary parameter to evaluate the structural performance among many other structural response parameters. In this research, the inter-story drift thresholds for frame are those suggested by FEMA-356 recommendation. For the frames modeled with both steel braces and masonry infill walls, in drift ratio ranges relevant to Immediate Occupancy up to about Life Safety, the threshold are assumed similar to that of masonry infill as the behavior of the structure is mainly governed by the masonry infills. In larger deformation ranges, the drift is practically controlled by the performance of the bracings as the infilled materials have been already crushed and disintegrated. Thus for collapse prevention criteria, the drift ratio thresholds for such frames are taken similar to the frame with bracings only. Such criteria is summarized in Table 4.

Table 4. Drift ratio thresholds corresponding to three structural damage states

Building Type	Drift Ratio at the Threshold of Structural Damage		
	Immediate Occupancy (IO)	Life Safety (LS)	Collapse Prevention (CP)
Masonry infill with bracing	0.003	0.006	0.02

## RESULTS - IDA AND FRAGILITY CURVES

Incremental Dynamic Analysis (IDA) is a technique to systematically process the effects of increasing earthquake ground motion intensity on structural response up to collapse (Vamvatsikos and Cornell, 2002). For IDA, a set of 44 ground motion records (recorded at 22 stations with 2 components) as offered by ATC-63 (FEMA P695) report was selected. At first, the records were normalized by their peak ground velocities and then scaled. The initial and the incremental spectral intensity at the first mode of the structure ( $S_{a-T1}$ ) are considered as 0.01g and 0.05g respectively. According to ATC-63 [8], the median of spectral intensities of all models need to be scaled to the desired intensity. The corresponding scale-factor should then be applied to all records in the set. The process continued up to any desired intensity level or even to the point of collapse of the system. Results of this procedure for extracting IDA curves is shown in Fig.9.

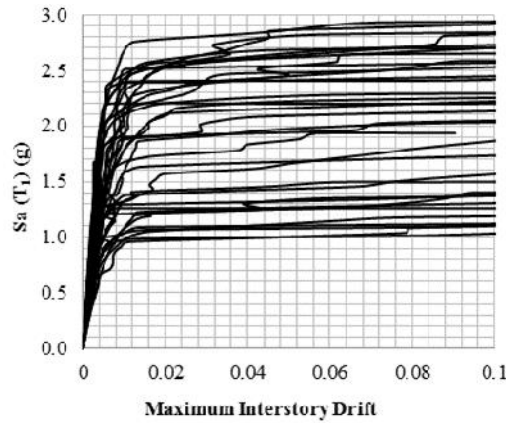

Figure 9. IDA curves of Khorjini structure with combination of infill and brace

A fragility curve is a measure for evaluating the performance of a particular construction exposed to hazard. For this research, the derived analytical fragility curves represent a continuous relationship between the intensity measure (IM) of ground motion as an input and the probability of exceedance for different damage states (DM). A generalized fragility function is expressed as:

$$F = P(d > DM_i | IM) \quad (1)$$

Where P is the probability for a certain damage level (d) exceeding a particular damage state ( $DM_i$ ) given a ground motion intensity measure (IM). In this paper, considering different applied ground motion records, the spectral acceleration for the first mode period of the structure ( $S_a(T_1)$ ) and the maximum inter-story drift specific to three damage states (Immediate Occupancy, Life Safety and Collapse Prevention) are selected as IM and  $DM_i$  where the probably density function is considered as lognormal. Highlighting different performance objectives, the derived fragility curves are shown in Figure 10.

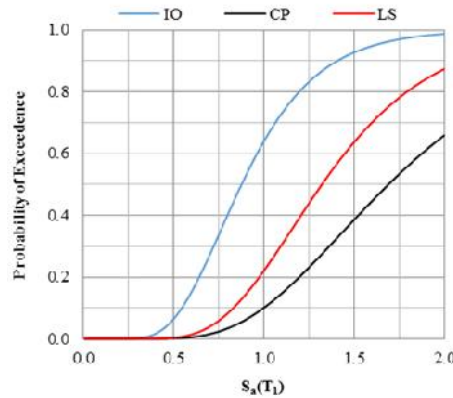

Figure 10. Fragility curves Khorjini structure with combination of infill and brace

Based on a recent report for Tehran region, Probabilistic Seismic Hazard Analysis (PSHA) results for three sites were performed by Gholipour *et al.* (2011). Based on this PSHA results for the area of interest, the spectral acceleration values at fundamental period of the buildings and the probability of exceeding three considered performance objectives, are shown in Table 5 considering two hazard levels. As it shows, the probability of exceeding all three damage states are reflecting high potential risks of these structural systems at future probable earthquakes.

Table 5. Probability of exceeding performance level in 475 and 2475 hazard levels

Lateral Load Resisting System	Hazard Level	$T_1$	$S_a(T_1)$ [g]	Probability of Exceedance (%)		
				IO	LS	CP
Combination of masonry infill and bracing	475	0.228	0.86	48	25	16
	2475		1.87	87	70	56



## CONCLUSIONS

Observing pushover and hysteretic curves, two distinct phases are observable during seismic lateral response. First, before infills' failure, the system has a high amount of lateral strength and stiffness. In the second phase (after failure of infills), the only-source for lateral stiffness and strength of the system is provided by the bracing elements and a drop in strength and stiffness occurs.

The results of the fragility analysis show that for three-story frames with the combination of infill wall and bracing, for an earthquake scenario with a return period of 2475 years, the probability of exceeding IO, LS and CP levels are 87%, 70% and 56% respectively. These probabilities are 48%, 25% and 16% for earthquakes scenario with a return period of 2475 years.

It seems that, generally, frames with semi-rigid saddle connections may not be safe for collapse prevention and also may not satisfy other performance levels in high seismicity sites. Therefore, it is believed that seismic retrofitting of such existing structures is quite essential.

## REFERENCES

Amiri H, Aghakouchak AA and Shakib H (2004) Performance assessment of steel braced frames with Saddle connections using capacity spectrum method. M.Sc. thesis, Department of Civil Engineering, TarbiatModares University, Tehran, [in Persian]

ATC-63, FEMA P695(2009) Quantification of building seismic performance factors. Prepared by Applied Technology Council for Federal Emergency Management Agency, Washington, DC

Crisafulli FJ (1997) Seismic behavior of reinforced concrete structures with masonry infills. Ph.D. Thesis, Department of Civil Engineering, University of Canterbury, New Zealand

FEMA 350 (2000) Recommended seismic design criteria for new steel moment frame buildings. Federal Emergency Management Agency, Washington, DC

FEMA 356 (2000) Prestandard and commentary for the seismic rehabilitation of buildings. Federal Emergency Management Agency. Washington, DC

Gholipour Y, Bozorgnia Y, Rahnama M, Berberian M, Ghoreishi M, Talebian N, Shaja-Taheri J and Shafeei A (2001) Probabilistic seismic hazard analysis phase I – greater Tehran regions – Final report – University of Tehran, Iran.

Karami R and Moghadam H (1991) Mechanical properties of Khorjini connections. M.Sc. thesis, Department of Civil Engineering, Sharif Technical University, Tehran, Iran

Mazroui A and Mostafai H (1999) Experimental investigation on new method of Khorjini connections under cyclic loads, Journal of New Building Housing, Building and Housing Research Center, autumn 1999, Period 4(2), p.2

McKenna F, Fenves G, Scott MH and Jeremic B (2000) Open System for Earthquake Engineering Simulation (OpenSees). Pacific Earthquake Engineering Research Center, University of California, Berkeley, CA

Moghadam H (2002) Earthquake engineering, fundamentals and application (Book in Persian). Farhang Pub, Tehran, Iran.

Vamvatsikos D and Cornell CA (2002) Incremental Dynamic Analysis. Earthquake Engineering and Structural Dynamics, 31(3): 491-514